

## General Description

The AAT8543 is a low threshold P-channel MOSFET designed for the battery, cell phone, and PDA markets. Using AnalogicTech's ultra-high-density MOSFET process and space-saving, small-outline, J-lead package, performance superior to that normally found in a TSOP-6 footprint has been squeezed into the footprint of an SC70JW-8 package.

## Applications

- Battery Packs
- Battery-Powered Portable Equipment
- Cellular and Cordless Telephones

## Absolute Maximum Ratings

$T_A = 25^\circ\text{C}$ , unless otherwise noted.

Symbol	Description	Value	Units	
$V_{DS}$	Drain-Source Voltage	-20	V	
$V_{GS}$	Gate-Source Voltage	$\pm 12$		
$I_D$	Continuous Drain Current @ $T_J = 150^\circ\text{C}^1$	$T_A = 25^\circ\text{C}$	$\pm 4.2$	A
		$T_A = 70^\circ\text{C}$	$\pm 3.3$	
$I_{DM}$	Pulsed Drain Current <sup>2</sup>	$\pm 20$		
$I_S$	Continuous Source Current (Source-Drain Diode) <sup>1</sup>	-1.2		
$T_J$	Operating Junction Temperature Range	-55 to 150	$^\circ\text{C}$	
$T_{STG}$	Storage Temperature Range	-55 to 150	$^\circ\text{C}$	

## Features

- Drain-Source Voltage (max): -20V
- Continuous Drain Current<sup>1</sup> (max): -4.2A @  $25^\circ\text{C}$
- Low On-Resistance:
  - $57\text{m}\Omega$  @  $V_{GS} = -4.5\text{V}$
  - $104\text{m}\Omega$  @  $V_{GS} = -2.5\text{V}$

## SC70JW-8 Package

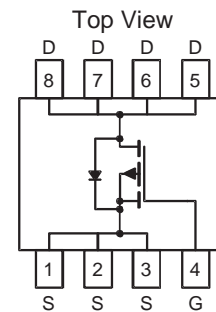

## Thermal Characteristics<sup>1</sup>

Symbol	Description	Typ	Max	Units
$R_{\theta JA}$	Typical Junction-to-Ambient Steady State	100	124	$^\circ\text{C}/\text{W}$
$R_{\theta JA2}$	Maximum Junction-to-Ambient $t < 5$ Seconds	62	76	$^\circ\text{C}/\text{W}$
$R_{\theta JF}$	Typical Junction-to-Foot	35	42	$^\circ\text{C}/\text{W}$
$P_D$	Maximum Power Dissipation	$T_A = 25^\circ\text{C}$	1.6	W
		$T_A = 70^\circ\text{C}$	1.0	

1. Based on thermal dissipation from junction to ambient while mounted on a 1" x 1" PCB with optimized layout. A 5-second pulse on a 1" x 1" PCB approximates testing a device mounted on a large multi-layer PCB as in most applications.  $R_{\theta JF} + R_{\theta FA} = R_{\theta JA}$  where the foot thermal reference is defined as the normal solder mounting surface of the device's leads.  $R_{\theta JF}$  is guaranteed by design; however,  $R_{\theta CA}$  is determined by the PCB design. Actual maximum continuous current is limited by the application's design.
2. Pulse test: Pulse Width = 300 $\mu\text{s}$ .

## Electrical Characteristics

$T_J = 25^\circ\text{C}$ , unless otherwise noted.

Symbol	Description	Conditions	Min	Typ	Max	Units
<b>DC Characteristics</b>						
$BV_{DSS}$	Drain-Source Breakdown Voltage	$V_{GS} = 0V, I_D = -250\mu A$	-20			V
$R_{DS(ON)}$	Drain-Source On-Resistance <sup>1</sup>	$V_{GS} = -4.5V, I_D = -4.2A$		45	57	m $\Omega$
		$V_{GS} = -2.5V, I_D = -3.1A$		80	104	
$I_{D(ON)}$	On-State Drain Current <sup>1</sup>	$V_{GS} = -4.5V, V_{DS} = -5V$ (pulsed)	-20			A
$V_{GS(th)}$	Gate Threshold Voltage	$V_{GS} = V_{DS}, I_D = -250\mu A$	-0.6			V
$I_{GSS}$	Gate-Body Leakage Current	$V_{GS} = \pm 12V, V_{DS} = 0V$			$\pm 100$	nA
$I_{DSS}$	Drain Source Leakage Current	$V_{GS} = 0V, V_{DS} = -20V$			-1	$\mu A$
		$V_{GS} = 0V, V_{DS} = -16V, T_J = 70^\circ\text{C}^2$			-5	
$g_{fs}$	Forward Transconductance <sup>1</sup>	$V_{DS} = -5V, I_D = -4.2A$		7		S
<b>Dynamic Characteristics<sup>2</sup></b>						
$Q_G$	Total Gate Charge	$V_{DS} = -10V, R_D = 2.4\Omega, V_{GS} = -4.5V$		8.5		nC
$Q_{GS}$	Gate-Source Charge	$V_{DS} = -10V, R_D = 2.4\Omega, V_{GS} = -4.5V$		1.5		
$Q_{GD}$	Gate-Drain Charge	$V_{DS} = -10V, R_D = 2.4\Omega, V_{GS} = -4.5V$		2.8		
$t_{D(ON)}$	Turn-On Delay	$V_{DS} = -10V, R_D = 2.4\Omega, V_{GS} = -4.5V, R_G = 6\Omega$		10		ns
$t_R$	Turn-On Rise Time	$V_{DS} = -10V, R_D = 2.4\Omega, V_{GS} = -4.5V, R_G = 6\Omega$		32		
$t_{D(OFF)}$	Turn-Off Delay	$V_{DS} = -10V, R_D = 2.4\Omega, V_{GS} = -4.5V, R_G = 6\Omega$		61		
$t_F$	Turn-Off Fall Time	$V_{DS} = -10V, R_D = 2.4\Omega, V_{GS} = -4.5V, R_G = 6\Omega$		38		
<b>Source-Drain Diode Characteristics</b>						
$V_{SD}$	Source-Drain Forward Voltage <sup>1</sup>	$V_{GS} = 0, I_S = -4.2A$			-1.3	V
$I_S$	Continuous Diode Current <sup>3</sup>				-1.2	A

1. Pulse test: Pulse Width = 300 $\mu s$ .

2. Guaranteed by design. Not subject to production testing.

3. Based on thermal dissipation from junction to ambient while mounted on a 1" x 1" PCB with optimized layout. A 5-second pulse on a 1" x 1" PCB approximates testing a device mounted on a large multi-layer PCB as in most applications.  $R_{\theta JF} + R_{\theta FA} = R_{\theta JA}$  where the foot thermal reference is defined as the normal solder mounting surface of the device's leads.  $R_{\theta JF}$  is guaranteed by design; however,  $R_{\theta CA}$  is determined by the PCB design. Actual maximum continuous current is limited by the application's design.

### Typical Characteristics

$T_J = 25^\circ\text{C}$ , unless otherwise noted.

**Output Characteristics**

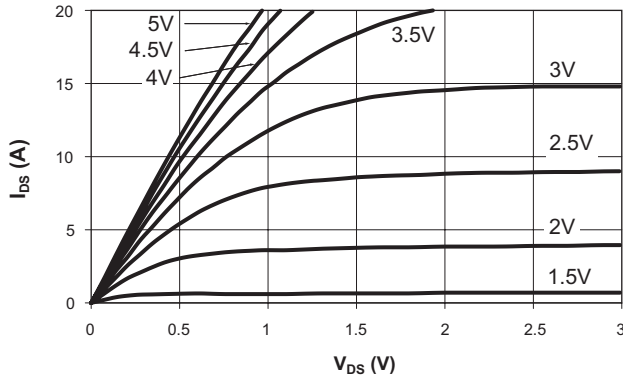

**Transfer Characteristics**

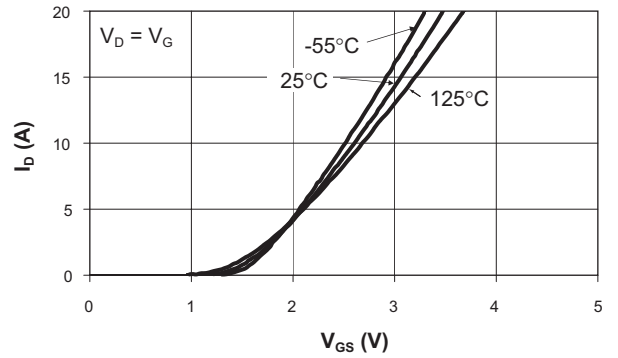

**On-Resistance vs. Drain Current**

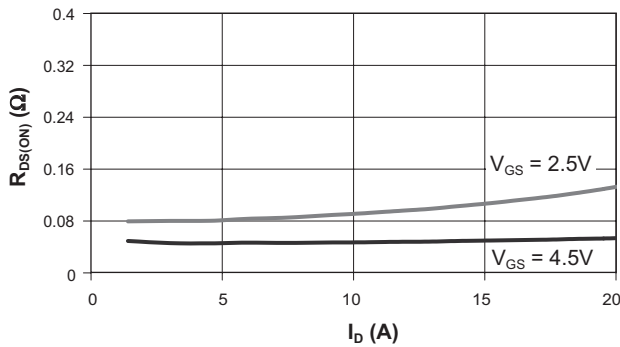

**On-Resistance vs. Gate-to-Source Voltage**

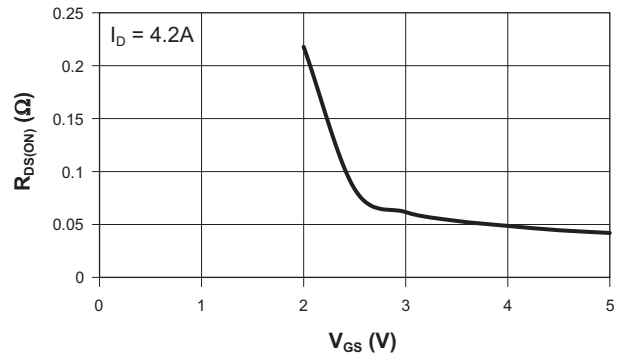

**On-Resistance vs. Junction Temperature**

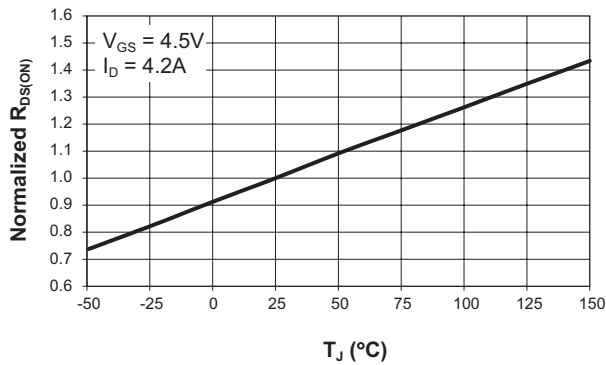

**Threshold Voltage**

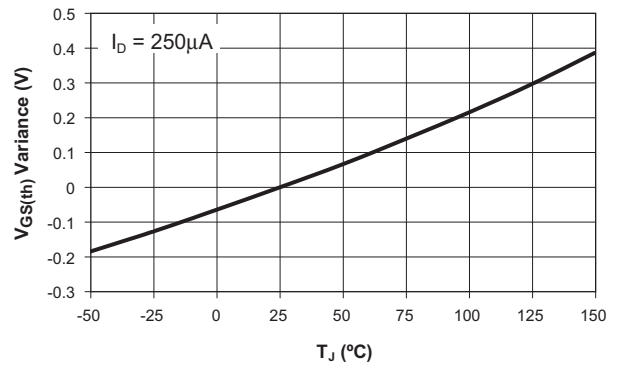

### Typical Characteristics

$T_J = 25^\circ\text{C}$ , unless otherwise noted.

**Gate Charge**

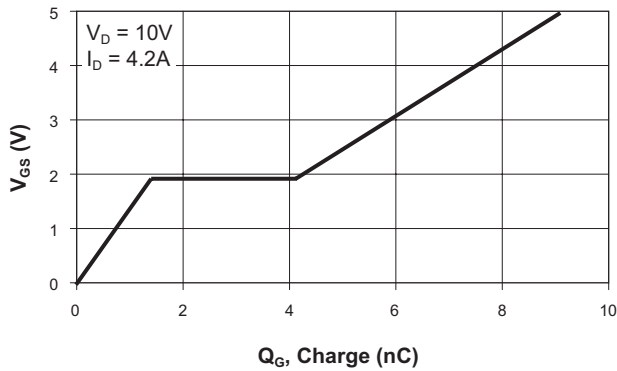

**Source-Drain Diode Forward Voltage**

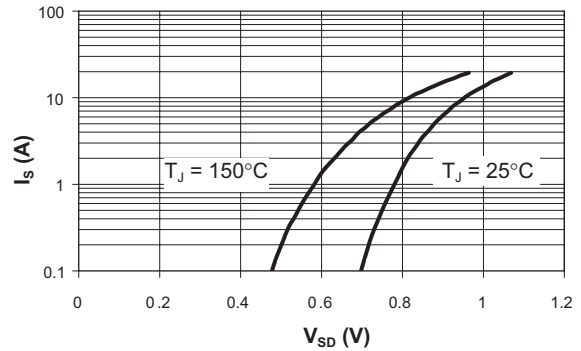

**Capacitance**

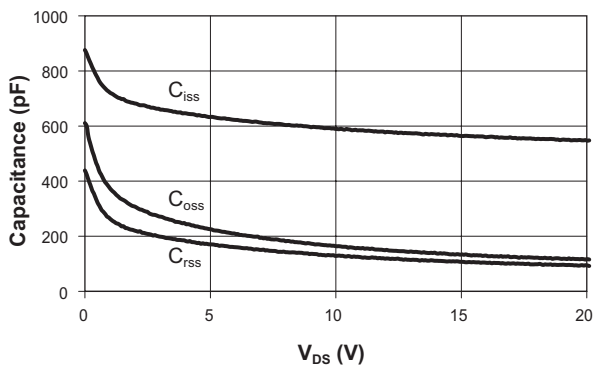

**Single Pulse Power, Junction to Ambient**

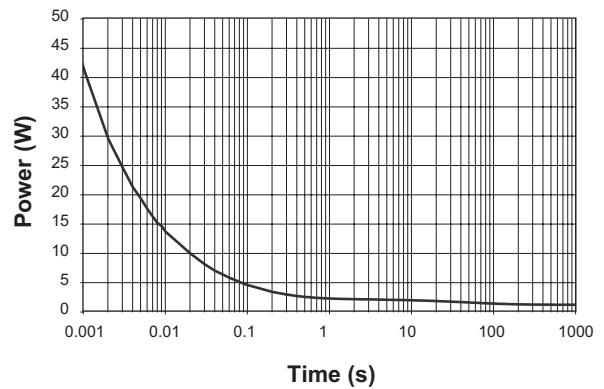

**Transient Thermal Response, Junction to Ambient**

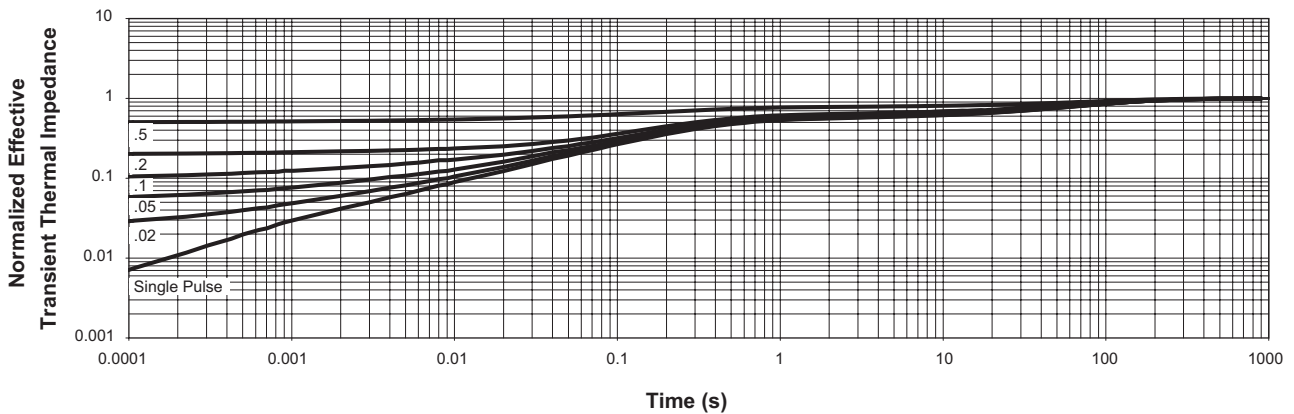

### Ordering Information

Package	Marking <sup>1</sup>	Part Number (Tape and Reel) <sup>2</sup>
SC70JW-8	JTXYY	AAT8543IJS-T1

### Package Information

#### SC70JW-8

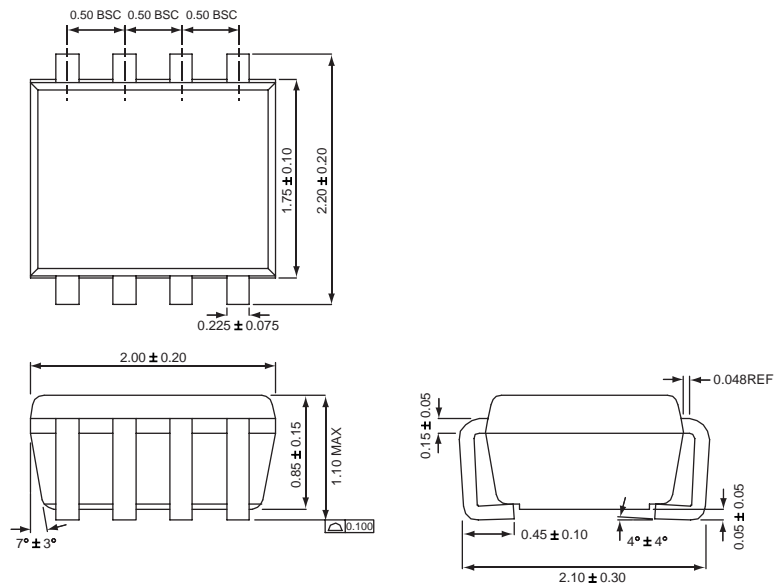

All dimensions in millimeters.

1. XYY = assembly and date code.  
 2. Sample stock is generally held on part numbers listed in **BOLD**.

AnalogicTech cannot assume responsibility for use of any circuitry other than circuitry entirely embodied in an AnalogicTech product. No circuit patent licenses, copyrights, mask work rights, or other intellectual property rights are implied.

AnalogicTech reserves the right to make changes to their products or specifications or to discontinue any product or service without notice, and advise customers to obtain the latest version of relevant information to verify, before placing orders, that information being relied on is current and complete. All products are sold subject to the terms and conditions of sale supplied at the time of order acknowledgement, including those pertaining to warranty, patent infringement, and limitation of liability.

AnalogicTech warrants performance of its semiconductor products to the specifications applicable at the time of sale in accordance with AnalogicTech's standard warranty. Testing and other quality control techniques are utilized to the extent AnalogicTech deems necessary to support this warranty. Specific testing of all parameters of each device is not necessarily performed.

**Advanced Analogic Technologies, Inc.**  
830 E. Arques Avenue, Sunnyvale, CA 94085  
Phone (408) 737-4600  
Fax (408) 737-4611

**This datasheet has been downloaded from:**

**[www.EEworld.com.cn](http://www.EEworld.com.cn)**

**Free Download**

**Daily Updated Database**

**100% Free Datasheet Search Site**

**100% Free IC Replacement Search Site**

**Convenient Electronic Dictionary**

**Fast Search System**

**[www.EEworld.com.cn](http://www.EEworld.com.cn)**