

APPLICATION MANUAL

LDO REGULATOR WITH ON/OFF SWITCH TK121xxCS

CONTENTS

1 . DESCRIPTION	2
2 . FEATURES	2
3 . APPLICATIONS	2
4 . PIN CONFIGURATION	2
5 . BLOCK DIAGRAM	2
6 . ORDERING INFORMATION	3
7 . ABSOLUTE MAXIMUM RATINGS	3
8 . ELECTRICAL CHARACTERISTICS	4
9 . TEST CIRCUIT	8
10 . APPLICATION EXAMPLE	8
11 . TYPICAL CHARACTERISTICS	9
12 . PIN DESCRIPTION	20
13 . APPLICATIONS INFORMATION	21
14 . NOTES	27
15 . OFFICES	27



LDO REGULATOR WITH ON/OFF SWITCH TK121xxCS

1. DESCRIPTION

The TK121xxCS is a low dropout linear regulator with ON/OFF control, which can supply 200mA load current. The output voltage, trimmed with high accuracy, is available from 1.5 to 5.0V in 0.1V steps. This allows the optimum voltage to be selected for the equipment.

The TK121xxCS is an integrated circuit with a silicon monolithic bipolar structure. This regulator IC is the low saturation voltage output type with very Low quiescent current.

The PNP pass transistor is built-in. The I/O voltage difference is 0.12V (typical) when a current of 100mA is supplied to the system. Because of the low voltage drop, the voltage source can be effectively used; this makes it very suitable for battery powered equipment.

The on/off function is built into the IC. The current during standby mode becomes very small (pA level). The over current sensor circuit and the reverse-bias protection circuit are built-in.

It is a very rugged design because the ESD protection is high. Therefore, the TK121xxCS can be used with confidence.

When mounted on the PCB, the power dissipation rating becomes about 500mW, even though the package is very small.

The TK121xxCS features very high stability in both DC and AC.

The capacitor on the output side provides stable operation with 0.1μF with 2.5V ≤ Vout. A capacitor of any type can be used; however, the larger this capacitor is, the better the overall characteristics are.

2. FEATURES

- On/Off Control available (High ON).
- Very Good Stability: Ceramic capacitor can be used.
: CL ≥ 0.1μF at Vout ≥ 2.5V
- High Precision Output Voltage (±1.5% or ±50mV)
- Excellent Ripple Rejection Ratio: -80dB at 1kHz
- Output Current: 200mA (peak 320mA)
- Very Low Dropout Voltage: 120mV at Iout=100mA
- Wide Operating Voltage Range: 2.1V~12V
- Very Low Noise with Noise Bypass pin
- Short Circuit Protection (Over Current Protection)
- Internal Thermal Shutdown (Over Heat Protection)
- Internal Reverse Bias Protection

3. APPLICATIONS

- Any Electronic Equipment
- Battery Powered Systems
- Mobile Communication

4. PIN CONFIGURATION

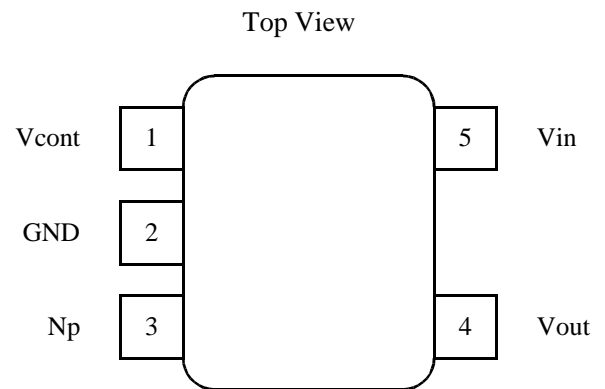

5. BLOCK DIAGRAM

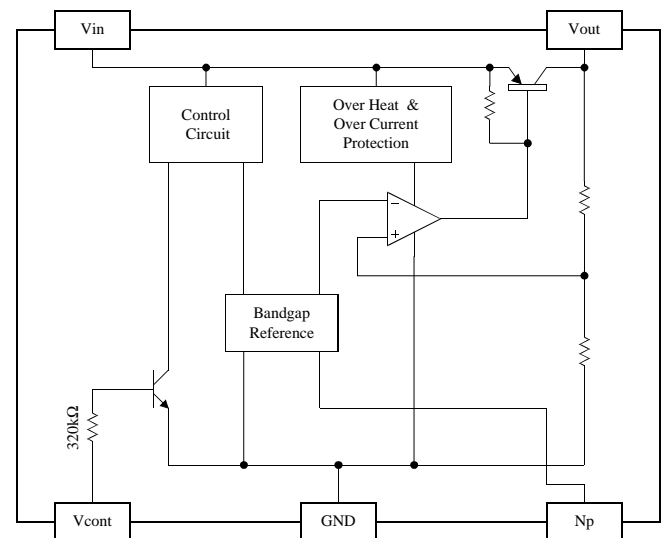

6. ORDERING INFORMATION

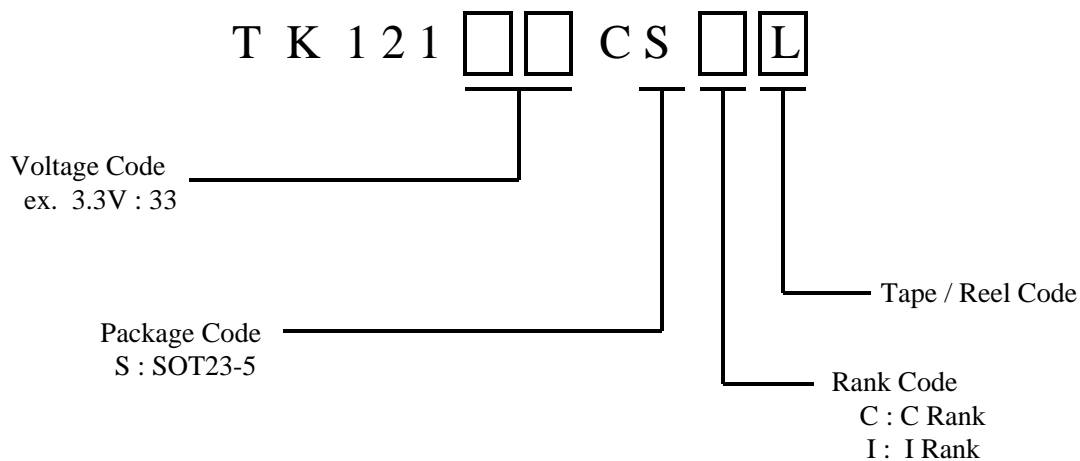

Standard Voltage (net multiplication bold-faced type)

TK12115CS	TK12118CS	TK12125CS	TK12128CS	TK12133CS
-----------	-----------	-----------	------------------	------------------

*Please contact your authorized TOKO representatives for voltage availability.
If you need the voltage except the above table, please contact TOKO.

7. ABSOLUTE MAXIMUM RATINGS

Ta=25°C

Parameter	Symbol	Rating	Units	Conditions
Absolute Maximum Ratings				
Supply Voltage	V _{CCMAX}	-0.4 ~ 16	V	
Reverse Bias	V _{revMAX}	-0.4 ~ 6	V	V _{out} ≤ 2.0V
		-0.4 ~ 12	V	2.1V ≤ V _{out}
Np pin Voltage	V _{npMAX}	-0.4 ~ 5	V	
Control pin Voltage	V _{contMAX}	-0.4 ~ 16	V	
Storage Temperature Range	T _{stg}	-55 ~ 150	°C	
Power Dissipation	P _D	500 when mounted on PCB	mW	Internal Limited T _j =150°C *
Operating Condition				
Operating Temperature Range	T _{OP}	-40 ~ 85	°C	
Operating Voltage Range	V _{OP}	2.1 ~ 12	V	
Short Circuit Current	I _{short}	360	mA	

* P_D must be decreased at rate of 4.0mW/°C for operation above 25°C.
The maximum ratings are the absolute limitation values with the possibility of the IC breakage.
When the operation exceeds this standard quality cannot be guaranteed.

8. ELECTRICAL CHARACTERISTICS

8-1. C Rank (TK121xxCSC)

The parameters with min. or max. values will be guaranteed at Ta=25°C with test when manufacturing or SQC(Statistical Quality Control) methods. The operation between -40 ~ 85°C is guaranteed when design.

$$V_{in}=V_{out_{TYP}}+1V, V_{cont}=0.9V, T_a=25^{\circ}C$$

Parameter	Symbol	Value			Units	Conditions
		MIN	TYP	MAX		
Output Voltage	Vout	Refer to TABLE 8-1-1 ~ 3			V	Iout = 5mA
Line Regulation	LinReg		0.0	5.0	mV	ΔVin = 5V
Load Regulation	LoaReg	Refer to TABLE 8-1-1 ~ 3			mV	Iout = 5mA ~ 100mA
		Refer to TABLE 8-1-1 ~ 3			mV	Iout = 5mA ~ 200mA
Dropout Voltage *1	Vdrop		80	140	mV	Iout = 50mA
			120	210	mV	Iout = 100mA
			230	350	mV	Iout = 180mA (2.1V ≤ Vout ≤ 2.3V)
			200	350	mV	Iout = 200mA (2.4V ≤ Vout)
Maximum Output Current *2	Iout_MAX	240	320		mA	When Vout down 0.3V
Supply Current	Icc	Refer to TABLE 8-1-1 ~ 3			μA	Iout = 0mA
Standby Current	Istandby		0.0	0.1	μA	Vcont = 0V
Quiescent Current	Iq		1.0	1.8	mA	Iout = 50mA
Control Terminal *3						
Control Current	Icont		0.7	2.0	μA	Vcont = 0.9V
Control Voltage	Vcont	0.9			V	Vout ON state
				0.2	V	Vout OFF state
Reference Value (TK12125CS)						
Np Terminal Voltage	Vnp		1.28		V	
Output Voltage / Temp.	Vo/Ta		35		ppm / °C	
Output Noise Voltage	Vno		34		μVrms	CL=1.0μF, Cnp=0.01μF Iout=30mA
Ripple Rejection	R.R		80		dB	CL=1.0μF, Cnp=0.001μF Iout=10mA, 1kHz
Rise Time	tr		36		μs	CL=1.0μF, Cnp=0.001μF Vcont: Pulse Wave (100Hz) Vcont ON → Vout×95% point

*1: For Vout ≤ 2.0V, not guaranteed.

*2: The maximum output current is limited by package power dissipation.

*3: The input current decreases to pA level when control terminal is connected to GND (Off state).

General Note: Parameter with only typical value is for reference only.

General Note: Output noise voltage can be reduced by connecting a capacitor to a noise bypass terminal (Np). The noise level depends on the capacitance and capacitor characteristics.

TABLE 8-1-1.Preferred Products

Part Number	Output Voltage			Load Regulation				Supply Current	
				Iout = 100mA		Iout = 200mA			
	MIN	TYP	MAX	TYP	MAX	TYP	MAX	TYP	MAX
	V	V	V	mV	mV	mV	mV	mA	mA
TK12128CSC	2.750	2.800	2.850	11	26	25	60	92	146
TK12133CSC	3.250	3.300	3.350	12	28	27	64	97	155

TABLE 8-1-2.Limited Availability Products

Part Number	Output Voltage			Load Regulation				Supply Current	
				Iout = 100mA		Iout = 200mA			
	MIN	TYP	MAX	TYP	MAX	TYP	MAX	TYP	MAX
	V	V	V	mV	mV	mV	mV	mA	mA
TK12115CSC	1.450	1.500	1.550	10	23	21	49	78	125
TK12118CSC	1.750	1.800	1.850	10	24	22	51	81	130
TK12125CSC	2.450	2.500	2.550	11	25	24	57	89	142

Notice.

Please contact your authorized TOKO representative for voltage availability.
 If you need the voltage except the above table, please contact TOKO.

8-2. I Rank (TK121xxCSI)

The parameters with min. or max. values will be guaranteed at Ta=-40~85°C with SQC(Statistical Quality Control) methods.

$$V_{in}=V_{out_{TYP}}+1V, V_{cont}=0.9V, T_a=-40 \sim 85^{\circ}C$$

Parameter	Symbol	Value			Units	Conditions
		MIN	TYP	MAX		
Output Voltage	Vout	Refer to TABLE 8-2-1 ~ 3			V	Iout = 5mA
Line Regulation	LinReg		0.0	8.0	mV	$\Delta V_{in} = 5V$
Load Regulation	LoaReg	Refer to TABLE 8-2-1 ~ 3			mV	Iout = 5mA ~ 100mA
		Refer to TABLE 8-2-1 ~ 3			mV	Iout = 5mA ~ 200mA
Dropout Voltage *1	Vdrop		80	180	mV	Iout = 50mA
			120	270	mV	Iout = 100mA
			230	390	mV	Iout = 180mA (2.2V ≤ Vout ≤ 2.3V)
			200	390	mV	Iout = 200mA (2.4V ≤ Vout)
Maximum Output Current *2	Iout _{MAX}	220	320		mA	When Vout down 0.3V
Supply Current	Icc	Refer to TABLE 8-2-1 ~ 3			μA	Iout = 0mA
Standby Current	Istandby		0.0	0.5	μA	Vcont = 0V
Quiescent Current	Iq		1.0	2.2	mA	Iout = 50mA
Control Terminal *3						
Control Current	Icont		0.7	2.5	μA	Vcont = 0.9V
Control Voltage	Vcont	0.9			V	Vout ON state
				0.2	V	Vout OFF state
Reference Value (TK12125CS)						
Np Terminal Voltage	Vnp		1.28		V	
Output Voltage / Temp.	Vo/Ta		35		ppm /°C	
Output Noise Voltage	Vno		34		μVrms	CL=1.0μF, Cnp=0.01μF Iout=30mA
Ripple Rejection	R.R		80		dB	CL=1.0μF, Cnp=0.001μF Iout=10mA, 1kHz
Rise Time	tr		36		μs	CL=1.0μF, Cnp=0.001μF Vcont: Pulse Wave (100Hz) Vcont ON → Vout×95% point

*1: For Vout ≤ 2.1V, not guaranteed.

*2: The maximum output current is limited by package power dissipation.

*3: The input current decreases to pA level when control terminal is connected to GND (Off state).

General Note: Parameter with only typical value is for reference only.

General Note: Output noise voltage can be reduced by connecting a capacitor to a noise bypass terminal (Np). The noise level depends on the capacitance and capacitor characteristics.

TABLE 8-2-1.Preferred Products

Part Number	Output Voltage			Load Regulation				Supply Current	
				Iout = 100mA		Iout = 200mA			
	MIN	TYP	MAX	TYP	MAX	TYP	MAX	TYP	MAX
	V	V	V	mV	mV	mV	mV	mA	mA
TK12128CSI	2.720	2.800	2.880	11	32	25	80	92	163
TK12133CSI	3.217	3.300	3.383	12	33	27	88	97	172

TABLE 8-2-2.Limited Availability Products

Part Number	Output Voltage			Load Regulation				Supply Current	
				Iout = 100mA		Iout = 200mA			
	MIN	TYP	MAX	TYP	MAX	TYP	MAX	TYP	MAX
	V	V	V	mV	mV	mV	mV	mA	mA
TK12115CSI	1.420	1.500	1.580	10	27	21	63	78	139
TK12118CSI	1.720	1.800	1.880	10	28	22	63	81	145
TK12125CSI	2.420	2.500	2.580	11	30	24	75	89	158

Notice.

Please contact your authorized TOKO representative for voltage availability.
 If you need the voltage except the above table, please contact TOKO.

9. TEST CIRCUIT

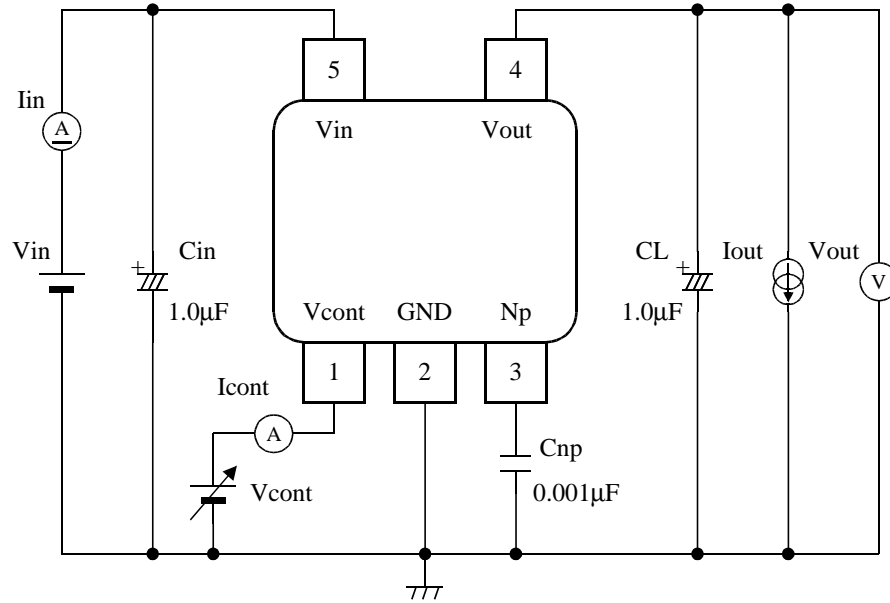

10. APPLICATION EXAMPLE

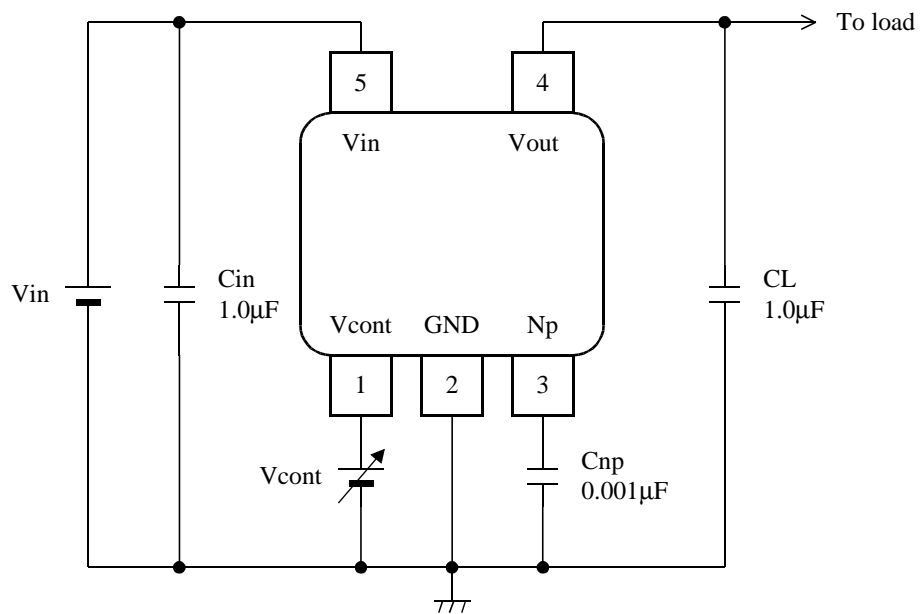

11. TYPICAL CHARACTERISTICS

11-1. DC CHARACTERISTICS

■ Line Regulation

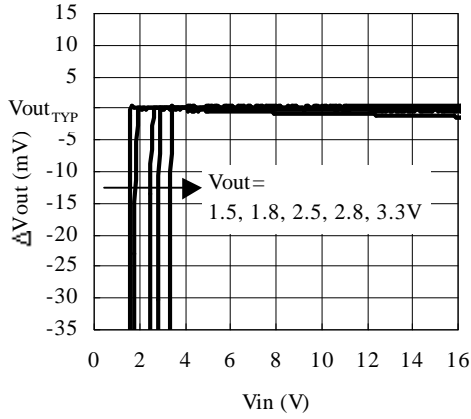

Test conditions

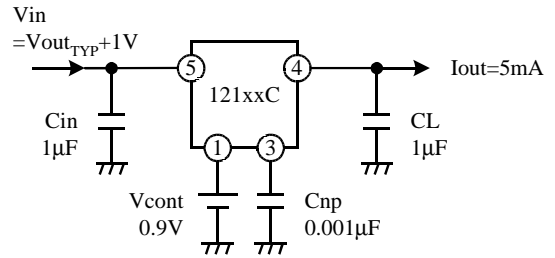

■ Vin vs Vout Regulation Point

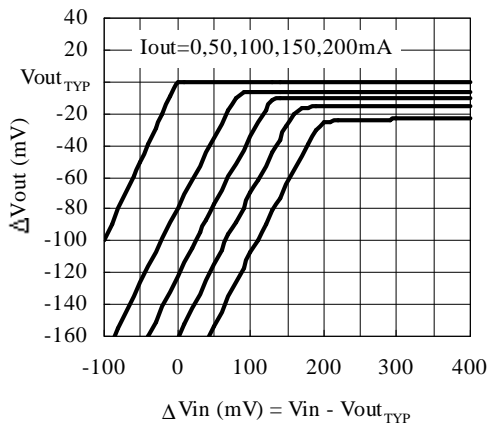

■ Load Regulation

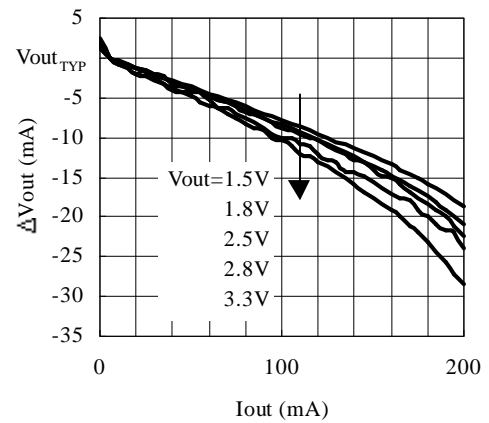

■ Dropout Voltage

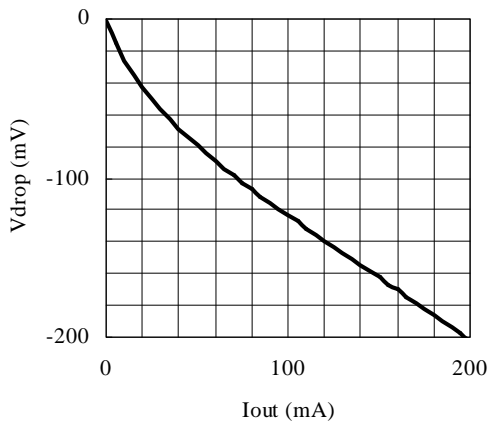

■ Short Circuit Current

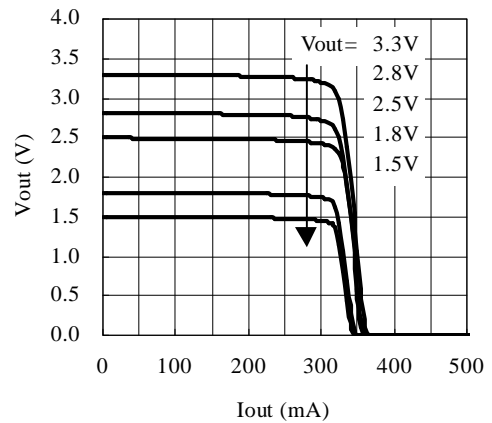

Test conditions: $V_{in}=V_{out_TYP}+1V$, $I_{out}=5mA$, $V_{cont}=0.9V$, $C_{in}=1\mu F$, $C_L=1\mu F$, $C_{np}=0.001\mu F$

■ Vin vs Iin (Iout=0mA)

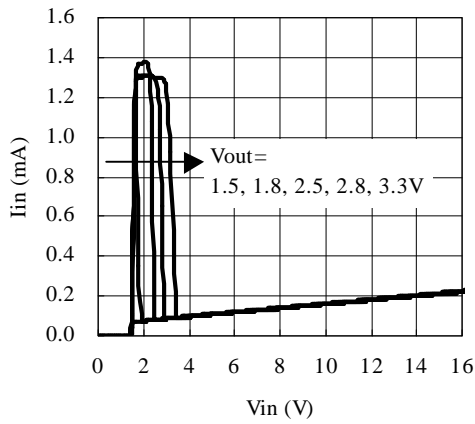

■ Vin vs Iin (Iout=0mA)

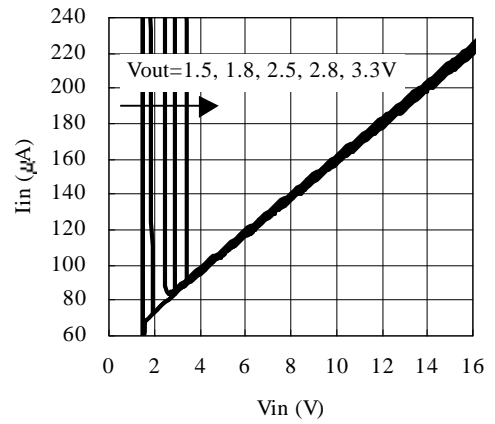

■ Standby Current (Vcont=0V)

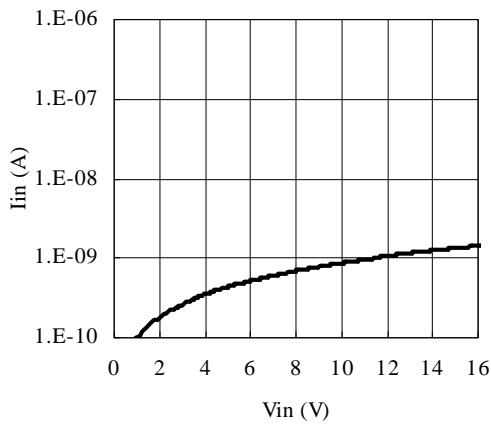

■ Quiescent Current

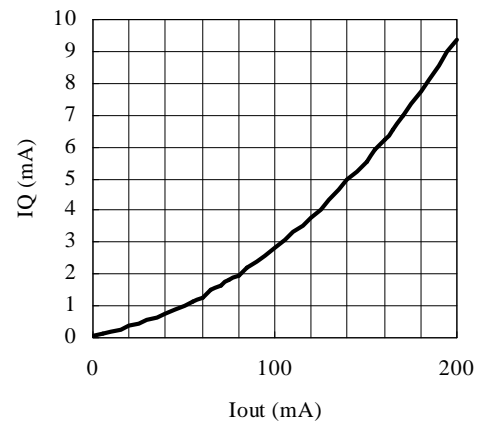

■ Vcont vs Icont , Vout

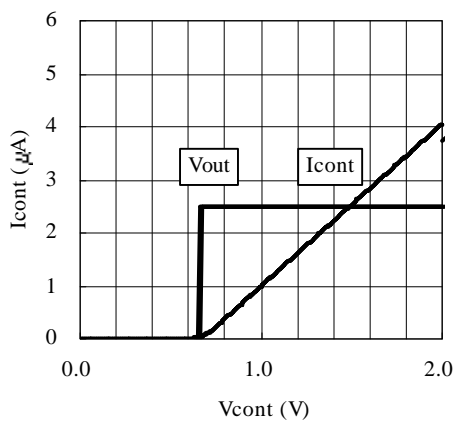

■ Reverse Bias Current

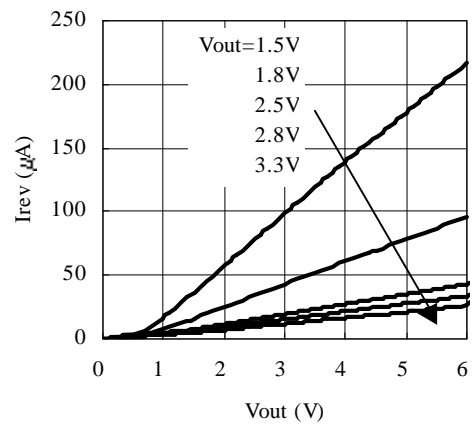

Temperature Characteristics

■ Vout
TK12125CS

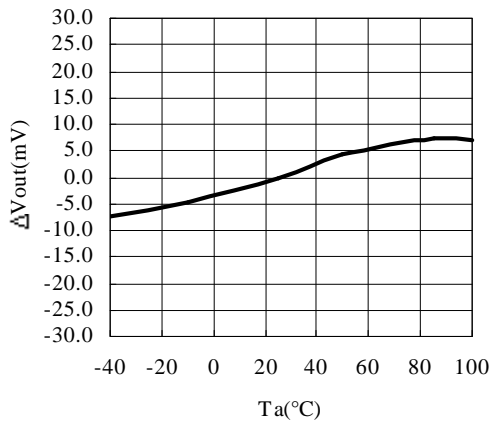

Test conditions

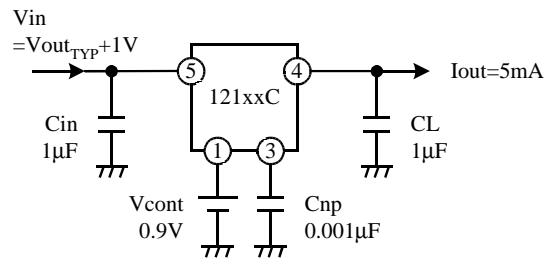

■ Line Regulation

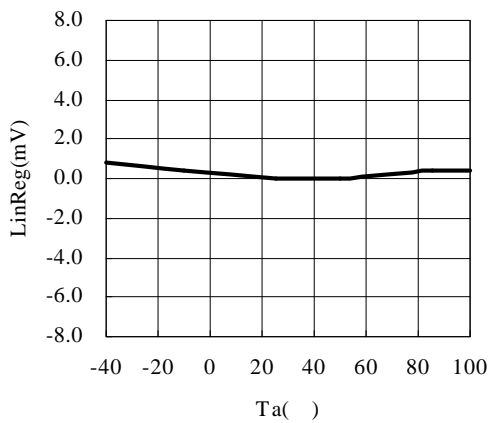

■ Load Regulation
TK12125CS

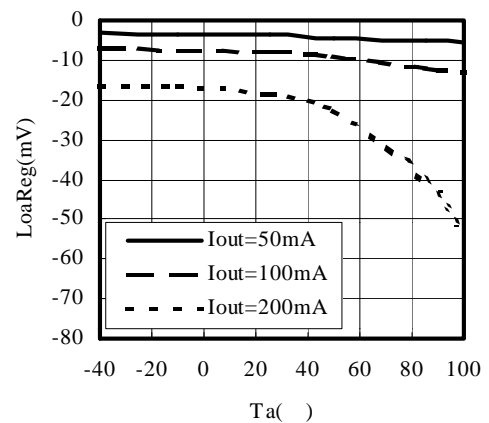

■ Dropout Voltage

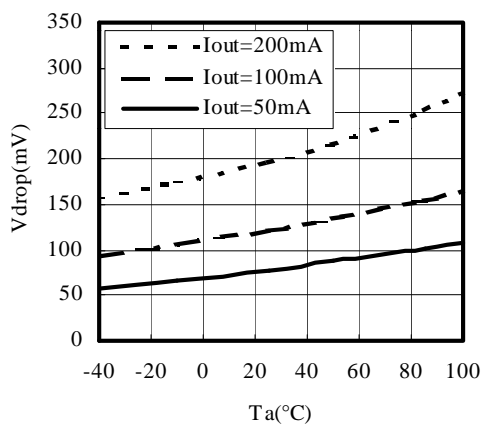

■ Iout MAX

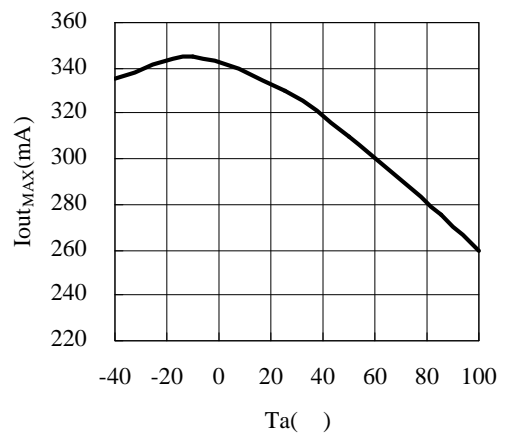

Test conditions: $V_{in}=V_{out_TYP}+1V$, $I_{out}=5mA$, $V_{cont}=0.9V$, $C_{in}=1\mu F$, $C_L=1\mu F$, $C_{np}=0.001\mu F$

■ Supply Current
TK12125CS ($V_{in}=3.5V$)

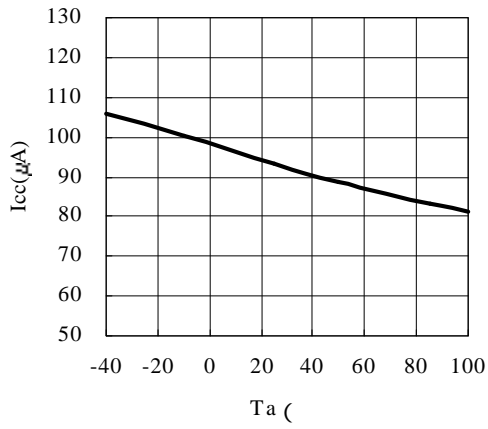

■ Quiescent Current

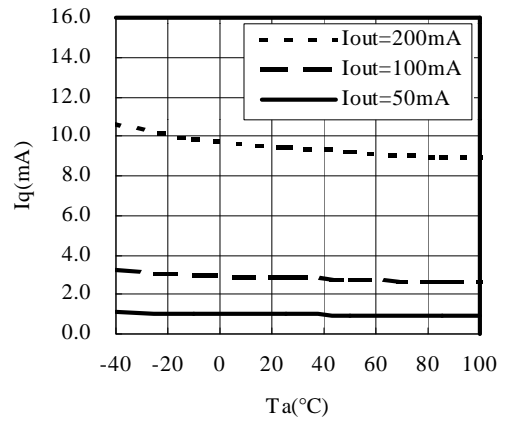

■ Control Current

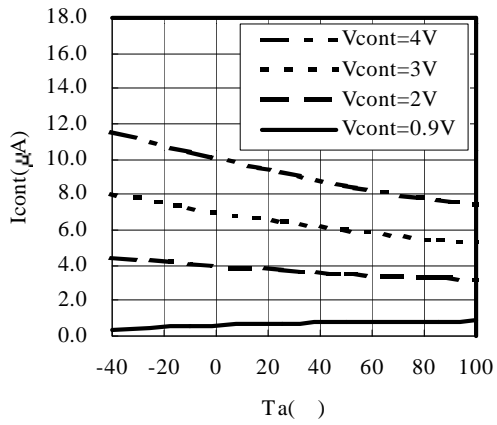

■ Control Voltage

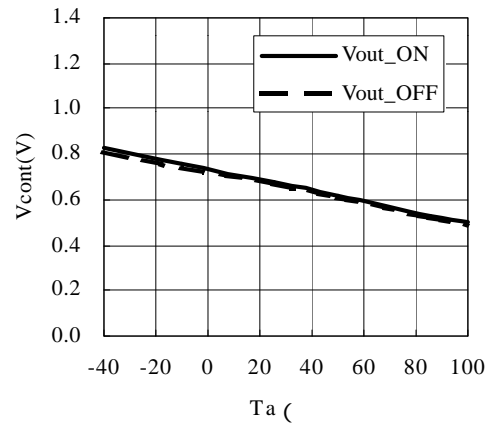

11-2. AC CHARACTERISTICS

Ripple Rejection

■ CL = 1μF: MLCC (C), Tantalum (T)
TK12125CS

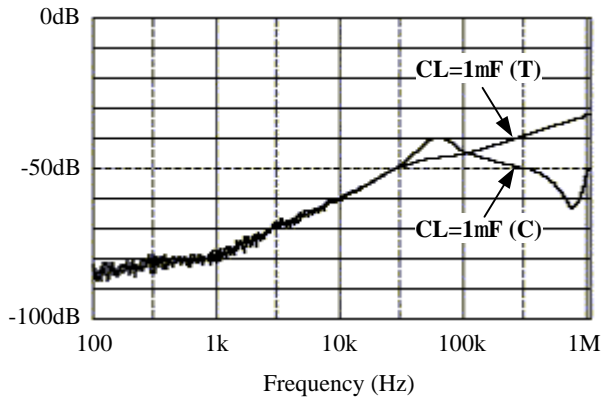

■ CL = 0.22μF: MLCC (C), Tantalum (T)
TK12125CS

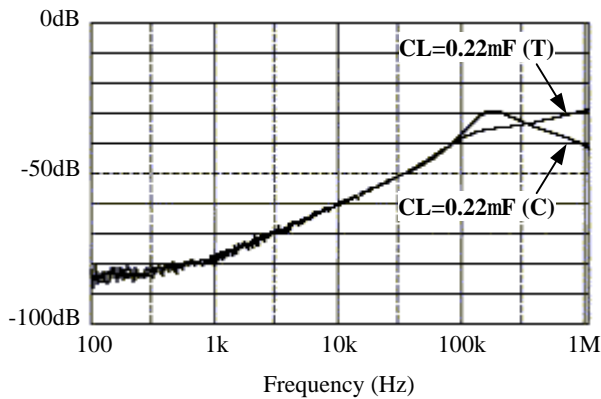

■ Cap = 0.001μF, 0.1μF: CL = 1.0μF Tantalum (T)
TK12125CS

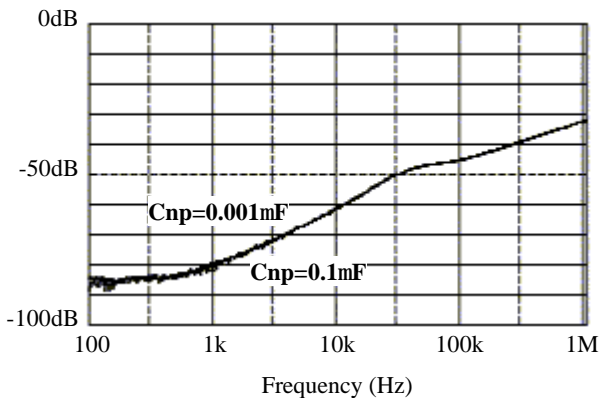

Test conditions

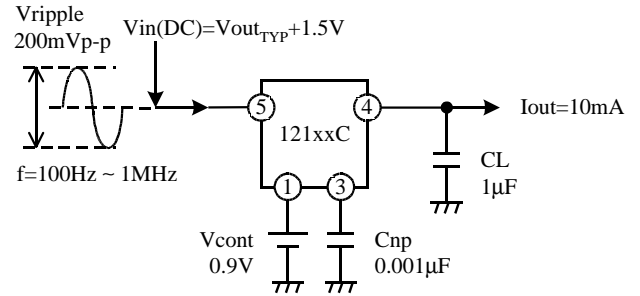

■ CL = 0.22μF, 10μF: Tantalum (T)
TK12125CS

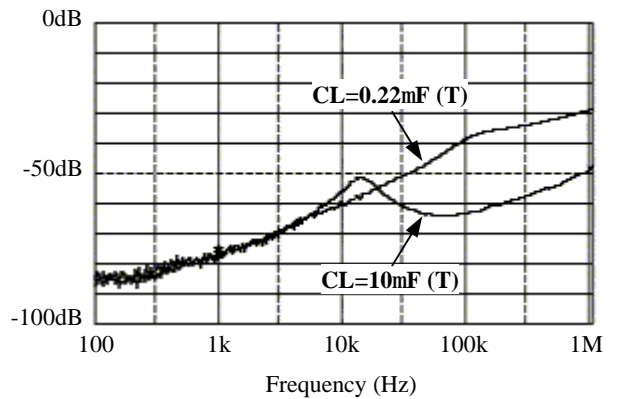

The ripple rejection characteristic depends on the characteristic and the capacitance value of the capacitor connected to the output side. The RR characteristic of 50kHz or more varies greatly with the capacitor on the output side and PCB pattern. If necessary, please confirm stability while operating.

Test conditions: $V_{in}=V_{out_TYP}+1.5V$, $I_{out}=10mA$, $V_{cont}=0.9V$, $C_L=1\mu F$ (Tantalum), $C_{np}=0.001\mu F$

■ TK12115CS

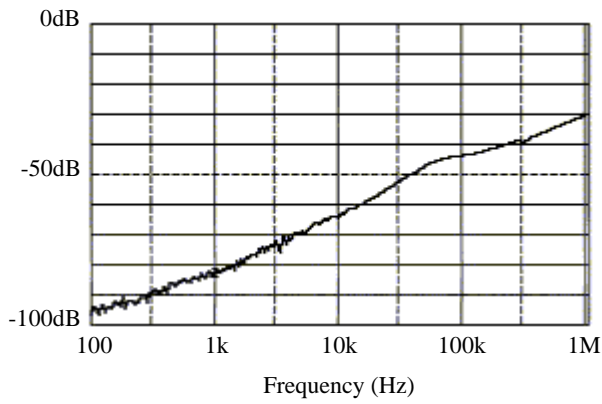

■ TK12118CS

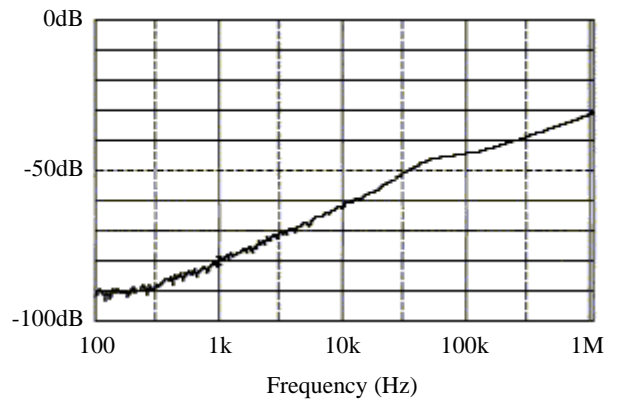

■ TK12125CS

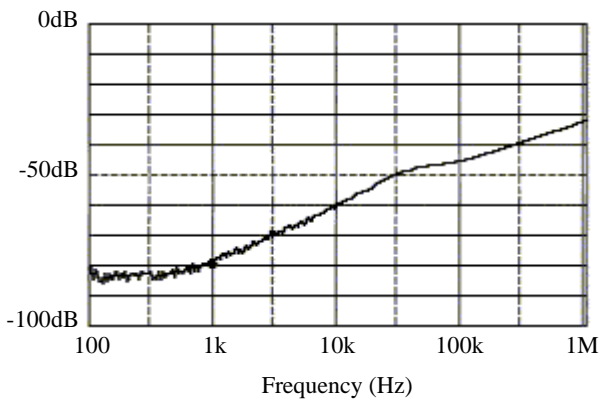

■ TK12128CS

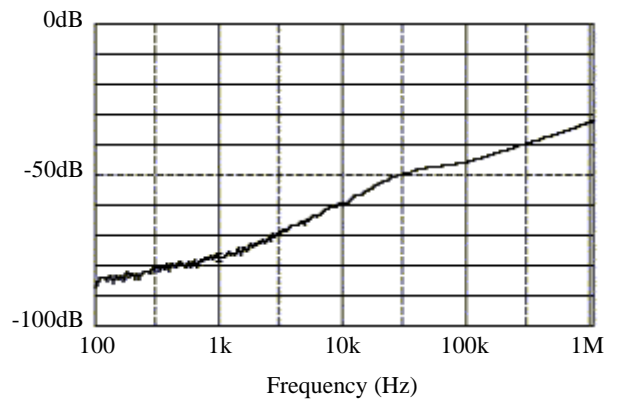

■ TK12133CS

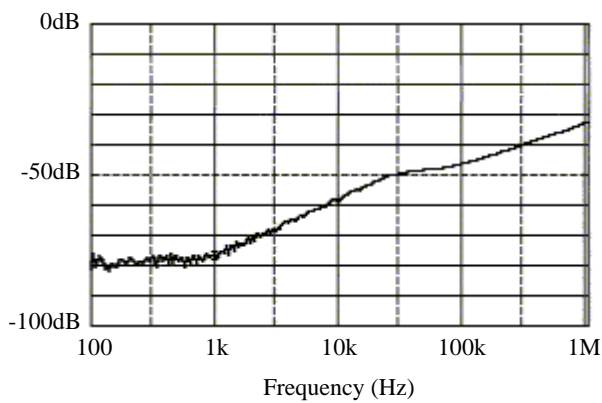

ON/OFF Transient

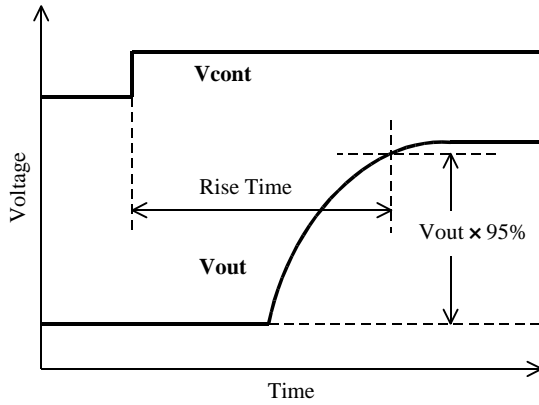

Test conditions

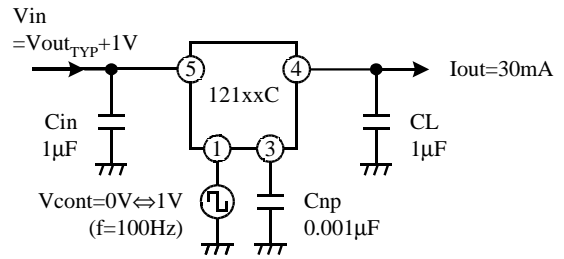

■ CL=0.22µF, 1.0µF, 2.2µF

■ CL=0.22µF, 1.0µF, 2.2µF

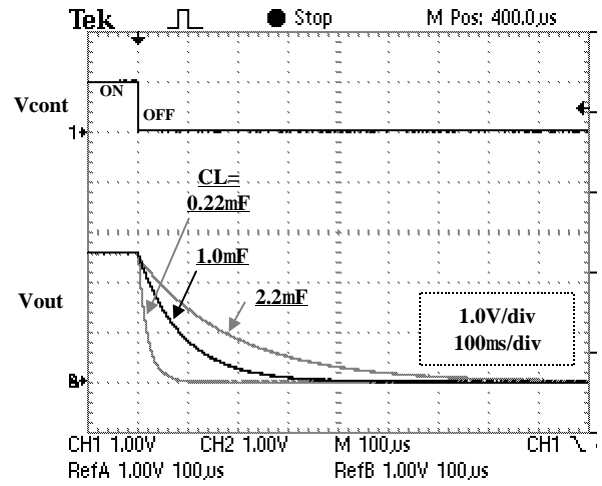
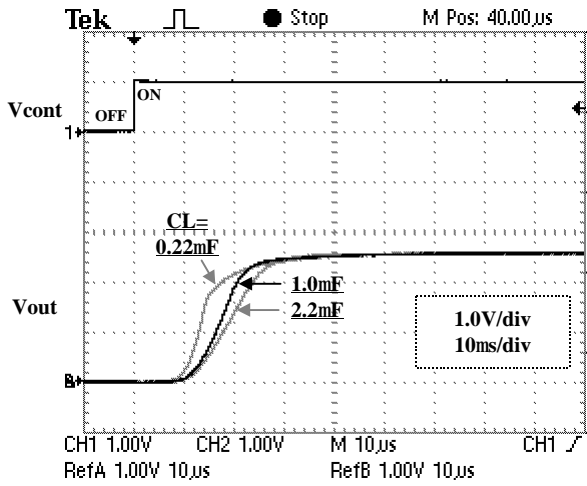

■ Cnp=0.001µF, 0.01µF

■ Cnp=0.001µF, 0.01µF, 0.1µF

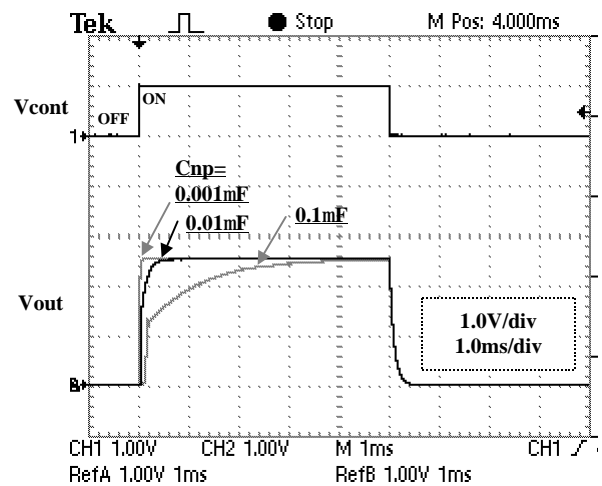
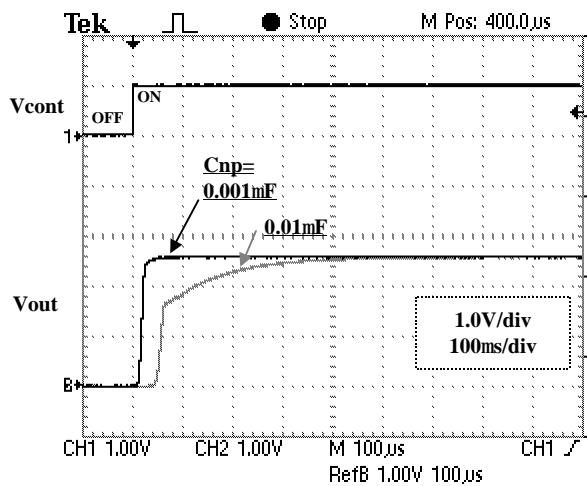

The rise time of the regulator depends on CL and Cnp; the fall time depends on CL.

Test conditions: $V_{in}=V_{out_{TYP}}+1V$, $I_{out}=30mA$, $V_{cont}=0V \leftrightarrow 1V$ (100Hz), $C_{in}=1\mu F$, $C_L=1\mu F$, $C_{np}=0.001\mu F$

- $V_{out}=1.5V, 1.8V, 2.5V, 2.8V, 3.3V$

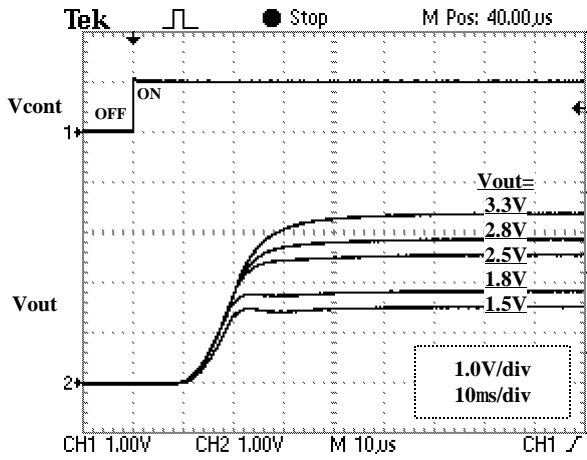

- $V_{out}=1.5V, 1.8V, 2.5V, 2.8V, 3.3V$
 V_{cont} : one pulse (after discharge C_{np}, C_L)

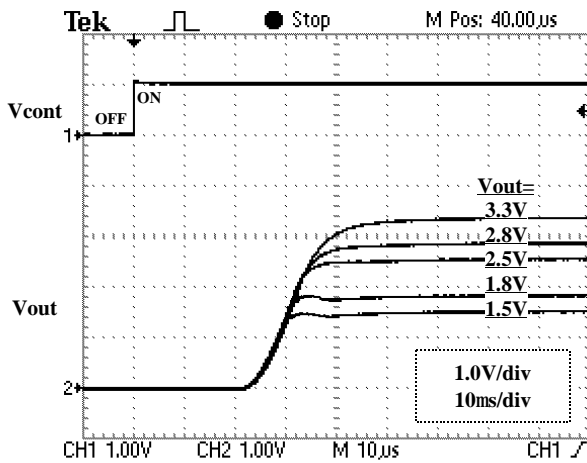

LOAD Transient

■ $CL=0.22\mu F, 1.0\mu F, 2.2\mu F: I_{out}=5\leftrightarrow 35mA$

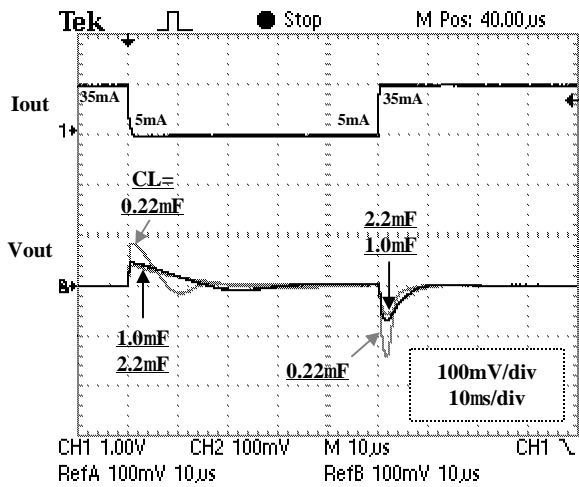

Test conditions

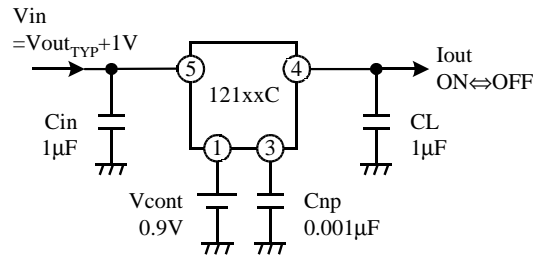

■ $I_{out}=0\leftrightarrow 30mA, 5\leftrightarrow 35mA$

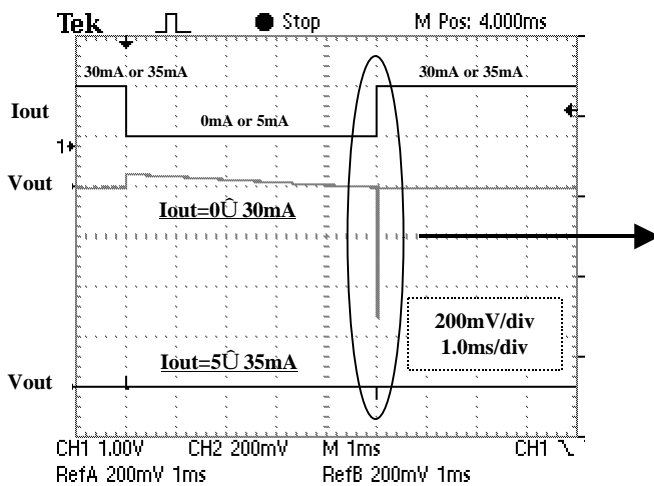

■ $I_{out}=0\Rightarrow 30mA, 5\Rightarrow 35mA$

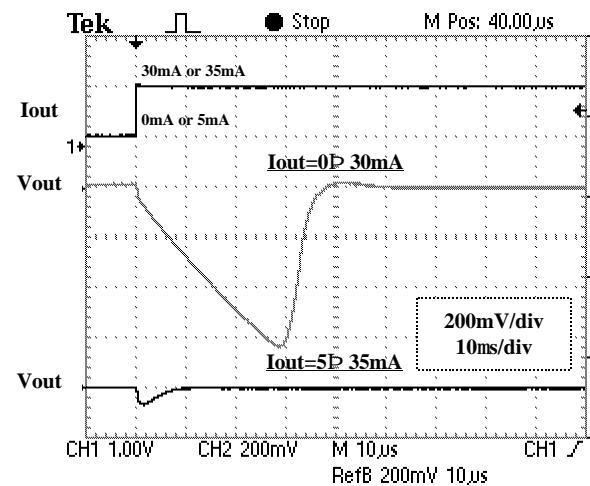

The no load voltage change can be greatly improved by delivering a little load current to ground (see the above curve).

Increase the load side capacitor when the load change is fast or when there is a large current change. In addition, at no load, delivering a little load current to ground can reduce the voltage change.

LINE Transient

- $CL=0.22\mu\text{F}, 1.0\mu\text{F}, 2.2\mu\text{F}$

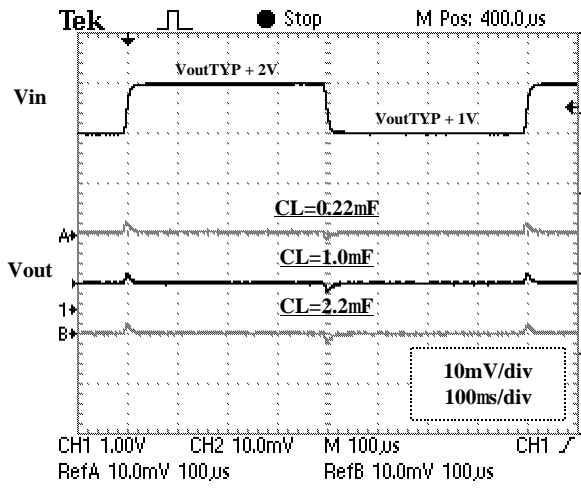

Test conditions

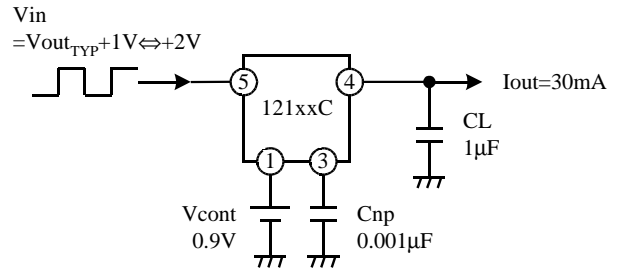

- $C_{np}=0.001\mu\text{F}, 0.01\mu\text{F}, 0.1\mu\text{F}$

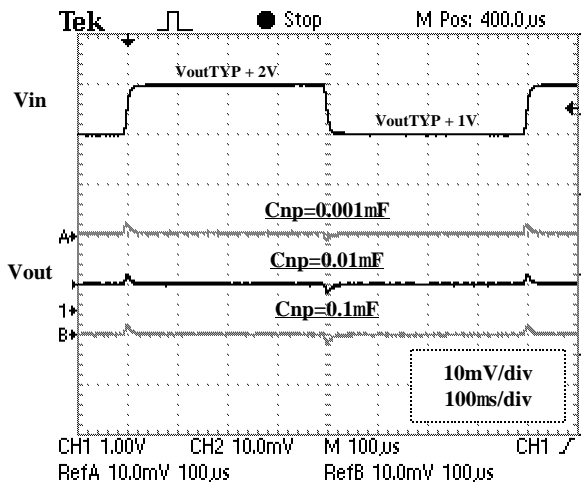

Output Noise Characteristics

■ Vout vs Noise

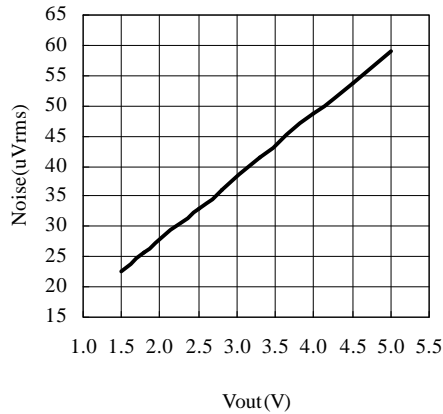

Test conditions

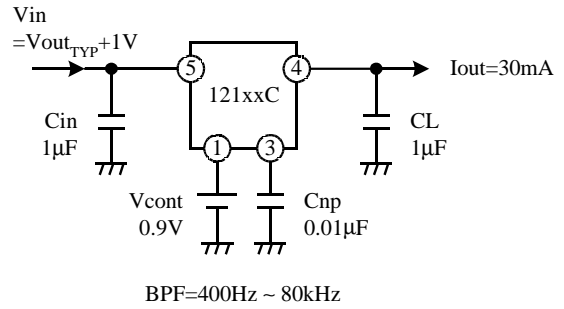

■ Cnp vs Noise (CL: Tantalum)
TK12125CS

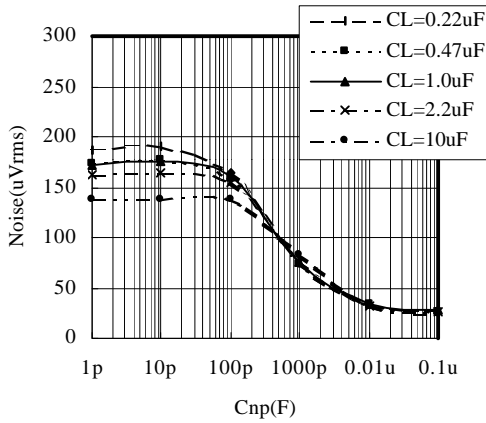

■ Cnp vs Noise (CL: MLCC)
TK12125CS

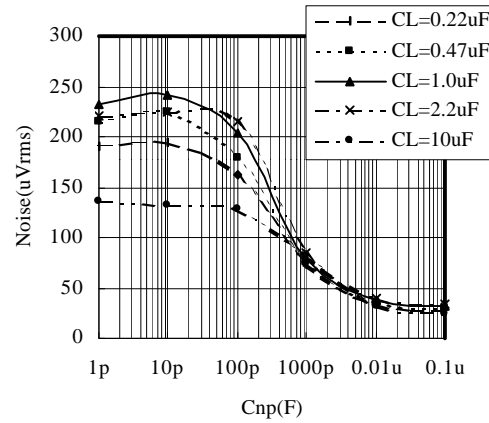

■ Iout vs Noise (CL: Tantalum)
TK12125CS

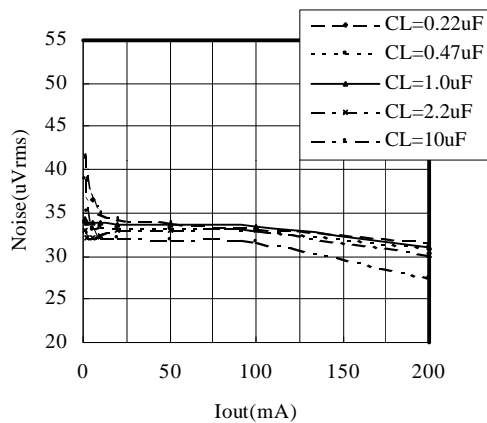

■ Iout vs Noise (CL: MLCC)
TK12125CS

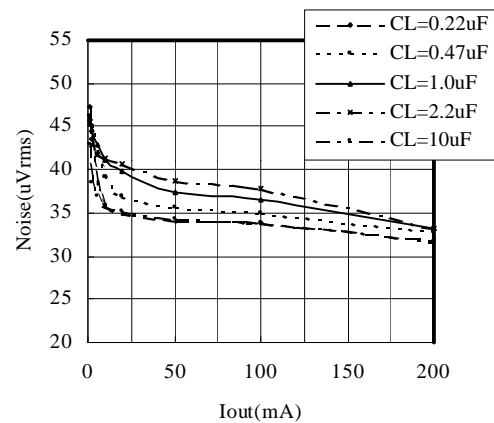

Increase Cnp to decrease the noise. The recommended Cnp capacitance is 0.0068μF ~ 0.01μF.
The amount of noise increases with the higher output voltages.

12. PIN DESCRIPTION

Pin No.	Pin Description	Internal Equivalent Circuit	Description
1	Vcont		<p>On/Off Control Terminal</p> <p>The pull down resistance is not built in.</p>
2	GND		GND Terminal
3	Np		<p>Noise Bypass Terminal</p> <p>Connect a bypass capacitor between GND.</p>
4	Vout		Output Terminal
5	Vin		Input Terminal

13. APPLICATIONS INFORMATION

13-1. Stability

Linear regulators require input and output capacitors in order to maintain the regulator's loop stability. If a 0.1μF capacitor is connected to the output side, the IC provides stable operation at any voltage in the practical current region. However, increase the CL capacitance when using the IC in the low current region and low voltage. Otherwise, the IC oscillates.

The equivalent series resistance (ESR) of the output capacitor must be in the stable operation area. However, it is recommended to use as large a value of capacitance as is practical. The output noise and the ripple noise decrease as the capacitance value increases. ESR values vary widely between ceramic and tantalum capacitors. However, tantalum capacitors are assumed to provide more ESR damping resistance, which provides greater circuit stability. This implies that a higher level of circuit stability can be obtained by using tantalum capacitors when compared to ceramic capacitors with similar values.

The input capacitor is necessary when the battery is discharged, the power supply impedance increases, or the line distance to the power supply is long.

This capacitor might be necessary on each individual IC even if two or more regulator ICs are used. It is not possible to determine this indiscriminately. Please confirm the stability while mounted

A recommended value of the application is as follows.

$$C_{in} = C_L \geq 0.22\mu F \text{ at } I_{out} \geq 0.5mA$$

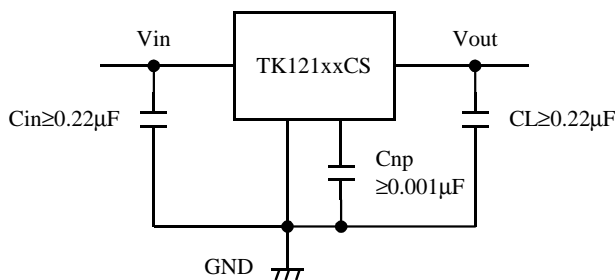

However, above recommended value is not satisfied some condition.

Refer to “Output Voltage, Output Current vs. Stable Operation Area“ at the next page.

Select the CL capacitance according to the condition of used.

If the fast road transient response is necessary, increase the CL capacitance as much as possible.

Output Voltage, Output Current vs. Stable Operation Area

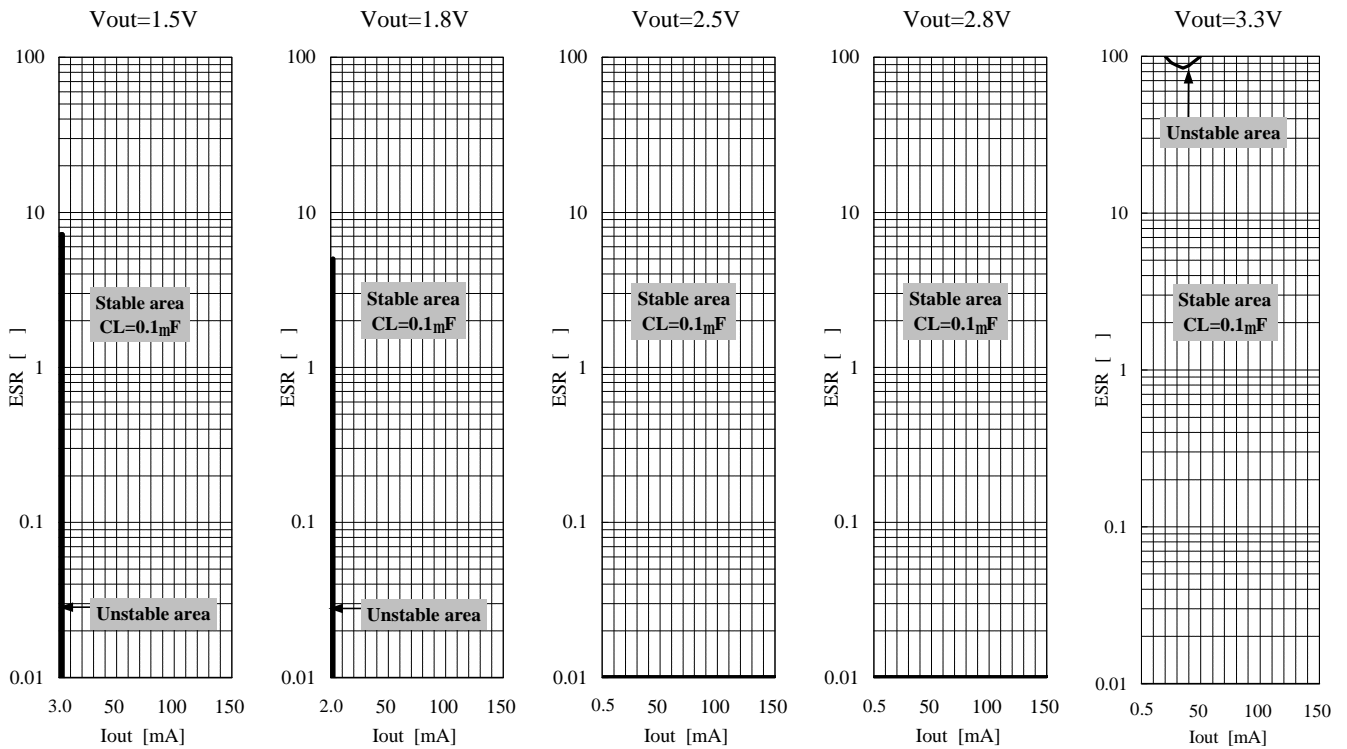

The above graphs show stable operation with a ceramic capacitor of 0.1μF (excluding the low current region). If the capacitance is not increased in the low voltage, low current area, stable operation may not be achieved. Please select the best output capacitor according to the voltage and current used. The stability of the regulator improves if a big output side capacitor is used (the stable operation area extends.) Please use as large a capacitance as is practical. Although operation above 150mA has not been described, stability is equal to or better than operation at 150mA.

ex. Ceramic Capacitance vs Voltage, Temperature

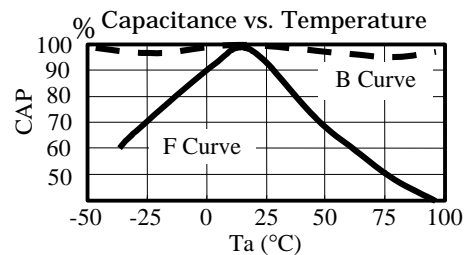
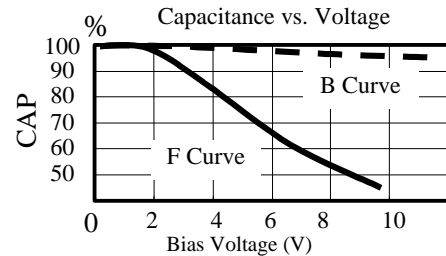

For evaluation

Kyocera: CM05B104K10AB, CM05B224K10AB, CM105B104K16A, CM105B224K16A, CM21B225K10A

Murata: GRM36B104K10, GRM42B104K10, GRM39B104K25, GRM39B224K10, GRM39B105K6.3

Generally, a ceramic capacitor has both a temperature characteristic and a voltage characteristic. Please consider both characteristics when selecting the part. The B curves are the recommend characteristics.

13-2. Definition of Technical Terms

.. **Output Voltage (Vout)**

The output voltage is specified with $V_{in}=(V_{out_TYP}+1V)$ and $I_{out}=5mA$.

.. **Maximum Output Current (Iout MAX)**

The rated output current is specified under the condition where the output voltage drops 0.3V the value specified with $I_{out}=5mA$. The input voltage is set to $V_{out_TYP}+1V$ and the current is pulsed to minimize temperature effect.

.. **Dropout Voltage (Vdrop)**

The dropout voltage is the difference between the input voltage and the output voltage at which point the regulator starts to fall out of regulation. Below this value, the output voltage will fall as the input voltage is reduced. It is dependent upon the load current and the junction temperature.

.. **Line Regulation (LinReg)**

Line regulation is the ability of the regulator to maintain a constant output voltage as the input voltage changes. The line regulation is specified as the input voltage is changed from $V_{in}=V_{out_TYP}+1V$ to $V_{in}=V_{out_TYP}+6V$. It is a pulse measurement to minimize temperature effect.

.. **Load Regulation (LoaReg)**

Load regulation is the ability of the regulator to maintain a constant output voltage as the load current changes. It is a pulsed measurement to minimize temperature effects with the input voltage set to $V_{in}=V_{out_TYP}+1V$. The load regulation is specified output current step conditions of 5mA to 100mA.

.. **Ripple Rejection (R.R)**

Ripple rejection is the ability of the regulator to attenuate the ripple content of the input voltage at the output. It is specified with $200mV_{rms}$, 1kHz super-imposed on the input voltage, where $V_{in}=V_{out}+1.5V$. Ripple rejection is the ratio of the ripple content of the output vs. input and is expressed in dB.

.. **Standby Current (Istandby)**

Standby current is the current, which flows into the regulator when the output is turned off by the control function ($V_{cont}=0V$).

.. **Over Current Sensor**

The over current sensor protects the device when there is excessive output current. It also protects the device if the output is accidentally connected to ground.

.. **Thermal Sensor**

The thermal sensor protects the device in case the junction temperature exceeds the safe value ($T_j=150^{\circ}C$). This temperature rise can be caused by external heat, excessive power dissipation caused by large input to output voltage drops, or excessive output current. The regulator will shut off when the temperature exceeds the safe value. As the junction temperatures decrease, the regulator will begin to operate again. Under sustained fault conditions, the regulator output will oscillate as the device turns off then resets. Damage may occur to the device under extreme fault.

Please reduce the loss of the regulator when this protection operate, by reducing the input voltage or make better heat efficiency.

* In the case that the power, $V_{in} \times I_{short}$ (Short Circuit Current), becomes more than twice of the maximum rating of its power dissipation in a moment, there is a possibility that the IC is destroyed before internal thermal protection works.

.. **Reverse Voltage Protection**

Reverse voltage protection prevents damage due to the output voltage being higher than the input voltage. This fault condition can occur when the output capacitor remains charged and the input is reduced to zero, or when an external voltage higher than the input voltage is applied to the output side

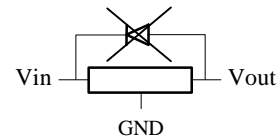

.. **ESD**

MM: 200pF 0Ω 200V or more

HBM: 100pF 1.5kΩ 2000V or more

13-3. Board Layout

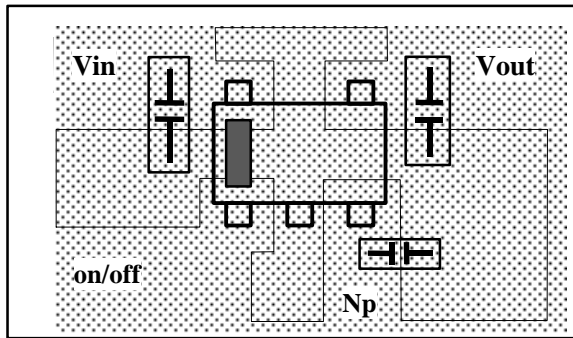

PCB Material: Glass epoxy (t=0.8mm)

Please do derating with 4.0mW/°C at Pd=500mW and 25°C or more. Thermal resistance (θja) is=250°C/W.

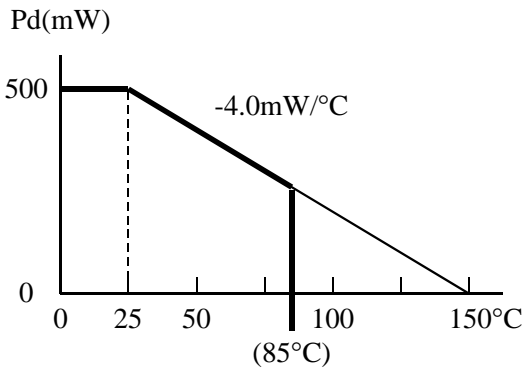

The package loss is limited at the temperature that the internal temperature sensor works (about 150°C). Therefore, the package loss is assumed to be an internal limitation. There is no heat radiation characteristic of the package unit assumed because of the small size. The device being mounted on the PCB carries heat away. This value changes by the material and the copper pattern etc. of the PCB. The losses are approximately 500mW. Enduring these losses becomes possible in a lot of applications operating at 25°C.

The overheating protection circuit operates when there are a lot of losses with the regulator (When outside temperature is high or heat radiation is bad). The output current cannot be pulled enough and the output voltage will drop when the protection circuit operates. When the junction temperature reaches 150°C, the IC is shut down. However, operation begins at once when the IC stops operation and the temperature of the chip decreases.

How to determine the thermal resistance when mounted on PCB

The thermal resistance when mounted is expressed as follows:

$$T_j = \theta_{ja} \times P_d + T_a$$

Tj of IC is set around 150°C. Pd is the value when the thermal sensor is activated.

If the ambient temperature is 25°C, then:

$$150 = \theta_{ja} \times P_d + 25$$

$$\theta_{ja} = 125 / P_d \text{ (}^\circ\text{C / mW)}$$

The simple method to calculate Pd

Mount the IC on the print circuit board. Short between the output pin and ground. after that, raise input voltage from 0V to evaluated voltage (see*1) gradually.

At shorted the output pin, the power dissipation Pd can be expressed as Pd=Vin × Iin.

The input current decreases gradually as the temperature of the chip becomes high. After a while, it reaches the thermal equilibrium. Use this current value at the thermal equilibrium. In almost all the cases, it shows 500mW or more.

*1 In the case that the power, Vin × Ishort(Short Circuit Current), becomes more than twice of the maximum rating of its power dissipation in a moment, there is a possibility that the IC is destroyed before internal thermal protection works.

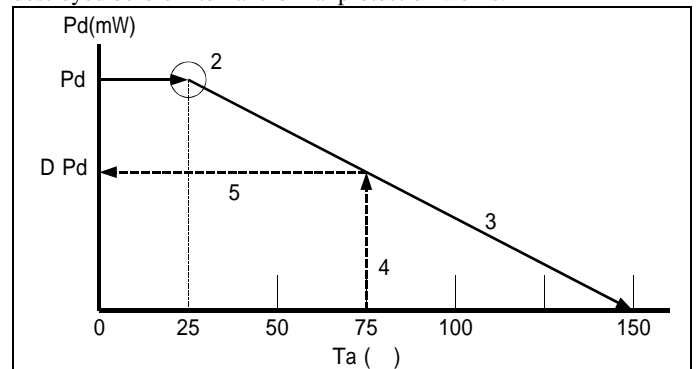

Procedure (When mounted on PCB.)

1. Find Pd (Vin×Iin when the output side is short-circuited).
2. Plot Pd against 25°C.
3. Connect Pd to the point corresponding to the 150°C with a straight line.
4. In design, take a vertical line from the maximum operating temperature (e.g., 75°C) to the derating curve.
5. Read off the value of Pd against the point at which the vertical line intersects the derating curve. This is taken as the maximum power dissipation DPd.
6. DPd ÷ (Vinmax-Vout)=Iout (at 75°C)

The maximum output current at the highest operating temperature will be Iout @ DPd, (VinMax- Vout).

Please use the device at low temperature with better radiation. The lower temperature provides better quality.

13-4. On/Off Control

It is recommended to turn the regulator off when the circuit following the regulator is non-operating. A design with little electric power loss can be implemented. We recommend the use of the on/off control of the regulator without using a high side switch to provide an output from the regulator. A highly accurate output voltage with low voltage drop is obtained.

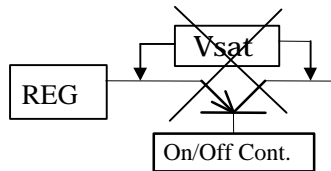

Because the control current is small, it is possible to control it directly by CMOS logic.

Parallel-Connected ON/OFF Control

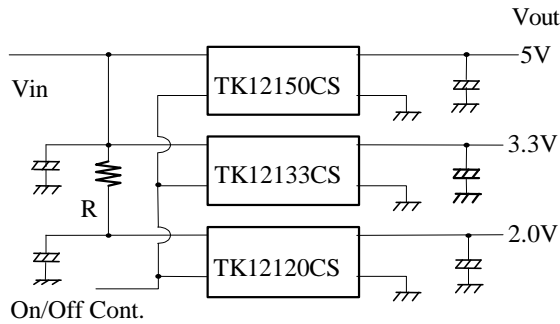

The above figure is multiple regulators being controlled by a single On/Off control signal. There is fear of overheating, because the power loss of the low voltage side IC (TK12120CS) is large. The series resistor (R) is put in the input line of the low output voltage regulator in order to prevent over-dissipation. The voltage dropped across the resistor reduces the large input-to-output voltage across the regulator, reducing the power dissipation in the device. When the thermal sensor works, a decrease of the output voltage, oscillation, etc. may be observed.

13-5. Noise Bypass

The noise and the ripple rejection characteristics depend on the capacitance on the Np terminal.

The ripple rejection characteristic of the low frequency region improves by increasing the capacitance of Cnp.

A standard value is Cnp=0.001μF. Increase Cnp in a design with important output noise and ripple rejection requirements. The IC will not be damaged if the capacitor value is increased.

The on/off switching speed changes depending on the Np terminal capacitance. The switching speed slows when the capacitance is large.

13-6. Outline; PCB; Stamps

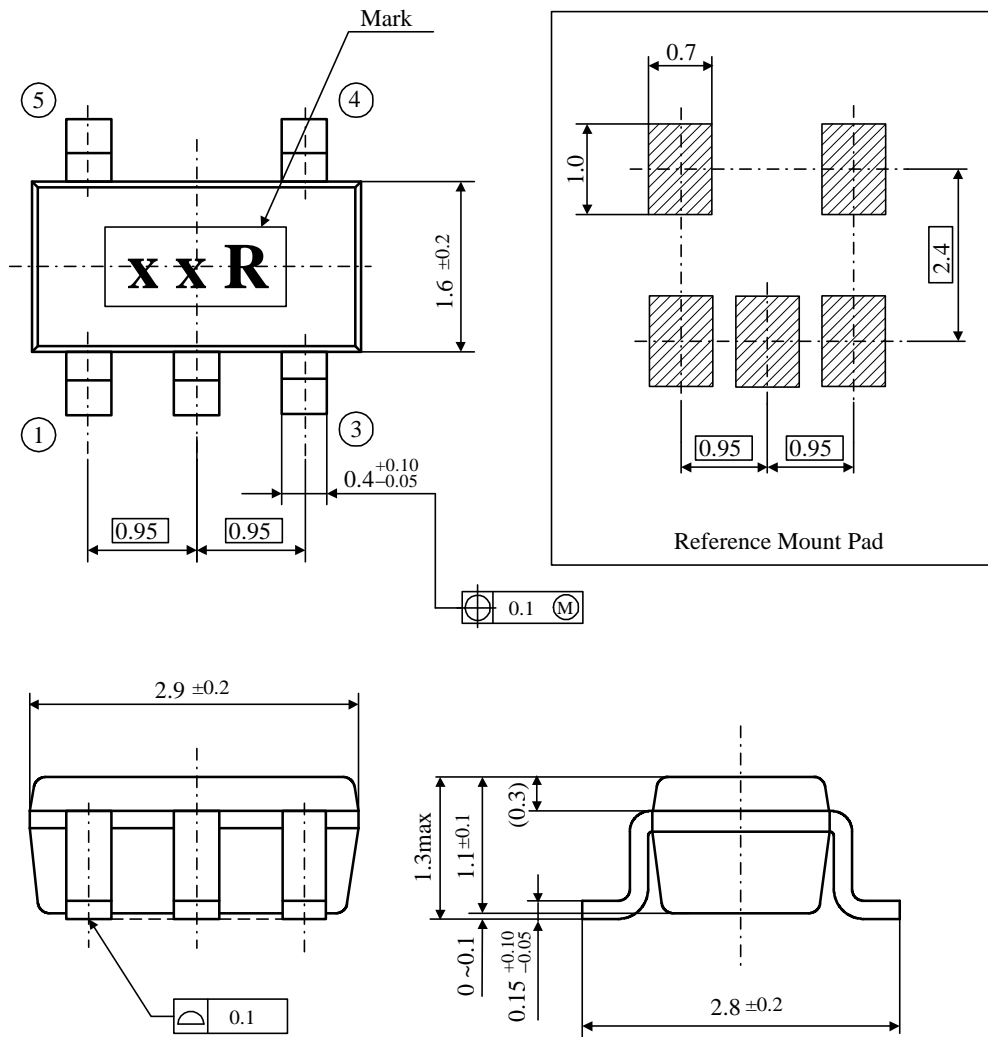

Unit: mm

Package Structure

Package Material: Epoxy Resin
 Terminal Material: Copper Alloy
 Mass (Reference): 0.016g

V OUT	V CODE	V OUT	V CODE	V OUT	V CODE
1.5V	15	2.5V	25	3.3V	33
1.8V	18	2.8V	28		

The output voltage table indicates the standard value when manufactured.
 Please contact your authorized Toko representative for voltage availability.

14. NOTES

- Please be sure that you carefully discuss your planned purchase with our office if you intend to use the products in this application manual under conditions where particularly extreme standards of reliability are required, or if you intend to use products for applications other than those listed in this application manual.
 - Power drive products for automobile, ship or aircraft transport systems; steering and navigation systems, emergency signal communications systems, and any system other than those mentioned above which include electronic sensors, measuring, or display devices, and which could cause major damage to life, limb or property if misused or failure to function.
 - Medical devices for measuring blood pressure, pulse, etc., treatment units such as coronary pacemakers and heat treatment units, and devices such as artificial organs and artificial limb systems which augment physiological functions.
 - Electrical instruments, equipment or systems used in disaster or crime prevention.

- Semiconductors, by nature, may fail or malfunction in spite of our devotion to improve product quality and reliability. We urge you to take every possible precaution against physical injuries, fire or other damages which may cause failure of our semiconductor products by taking appropriate measures, including a reasonable safety margin, malfunction preventive practices and fire-proofing when designing your products.

- This application manual is effective from Oct 2002. Note that the contents are subject to change or discontinuation without notice. When placing orders, please confirm specifications and delivery condition in writing.

- TOKO is not responsible for any problems nor for any infringement of third party patents or any other intellectual property rights that may arise from the use or method of use of the products listed in this application manual. Moreover, this application manual does not signify that TOKO agrees implicitly or explicitly to license any patent rights or other intellectual property rights which it holds.

- None of the ozone depleting substances(ODS) under the Montreal Protocol are used in our manufacturing process.

15. OFFICES

If you need more information on this product and other TOKO products, please contact us.

- TOKO Inc. Headquarters
 1-17, Higashi-yukigaya 2-chome, Ohta-ku, Tokyo,
 145-8585, Japan
 TEL: +81.3.3727.1161
 FAX: +81.3.3727.1176 or +81.3.3727.1169
 Web site: <http://www.toko.co.jp/>

- TOKO America
 Web site: <http://www.toko.com/>

- TOKO Europe
 Web site: <http://www.tokoeurope.com/>

- TOKO Hong Kong
 Web site: <http://www.toko.com.hk/>

- TOKO Taiwan
 Web site: <http://www.tokohc.com.tw/>

- TOKO Singapore
 Web site: <http://www.toko.com.sg/>

- TOKO Seoul
 Web site: <http://www.toko.co.kr/>

- TOKO Manila
 Web site: <http://www.toko.com.ph/>

- TOKO Brazil
 Web site: <http://www.toko.com.br/>



TO BUILD THE QUALITY RELIED UPON BY CUSTOMERS
Semiconductor Division

YOUR DISTRIBUTOR